

# BIOSHELTER GUIDEBOOK

BIOSHELTER RESEARCH BY NEW ALCHEMY INSTITUTE (1971-1991)

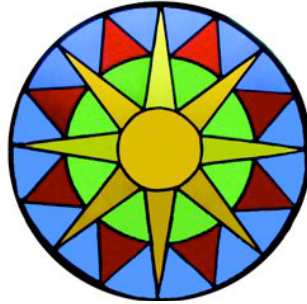

"Let us imagine an enclosure of virtually any scale that lets sunlight into itself and that prevents heat from escaping when the interior microclimate is too cool. It also reflects sunlight, and it dumps heat out into the night sky when its interior is too warm. Let us further conceive that, within this enclosure, sufficient heat could be stored in the ground to provide several days worth, even if the sun did not shine. We would then have a system that would maintain a very stable interior microclimate without requiring mechanical heating or cooling. Let us then also imagine a building that is designed not only to provide shelter from the weather, but also to provide some food; fresh water; liquid and solid waste disposal; space heating and cooling; power for cooking and refrigeration; and electricity for communications, lighting and household appliances."

Sean Wellesley-Miller and Day Chahroudi.  
"Bioshelter" *Architecture Plus* Nov/Dec 1974

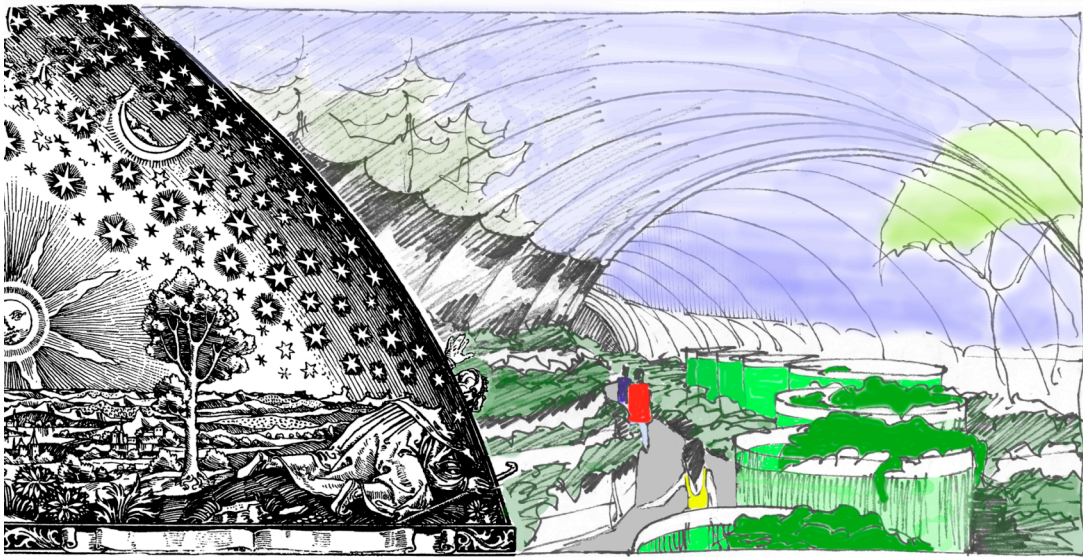

*From 1971 to 1991, the New Alchemy Institute conducted research and education on behalf of the planet. Among its major tasks was the creation of ecologically derived human support systems – renewable energy, agriculture, aquaculture, housing and landscapes. One of its major achievements was the testing of bioshelters – solar greenhouses which enclose ecosystems of food crops, fish ponds, soil life, and indoor wildlife .s.*

*This Guidebook is a brief overview of New Alchemy's research into bioshelters, including prototypes that were built, conceptual designs, and computer models of imaginary structures.* Earle Barnhart

## Early Domes - 1971-1981

New Alchemy's first proto-bioshelter was a small cheap plastic dome placed over a small cheap inflated wading pool. The pond was used to grow edible Tilapia fish.

Several larger domes (polyethylene on wood frame) were built over in-ground ponds lined with polyethylene. Food plants were grown in the soil around the pond and were irrigated with warm, nutrient-rich pond water. Later a stronger dome was made with a wood frame and double-glazed fiberglass, over a 3000 gallon in-ground plastic-lined pond.

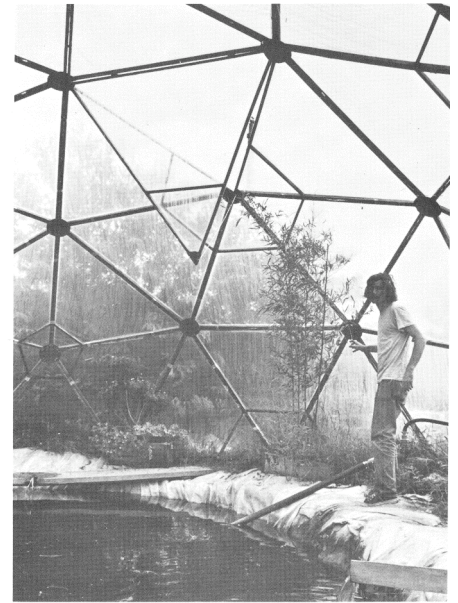

## Mini-Ark - 1973

- This structure tested more durable materials :
- a low-slope plexiglass cover over an insulated cement fishpond
- reflective insulated north wall

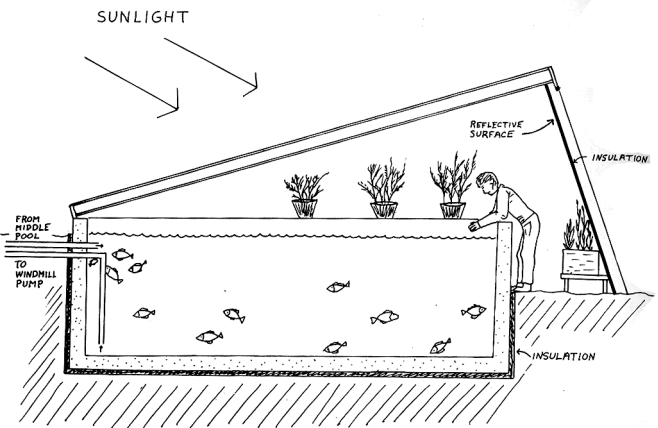

## The "Six-Pack" Backyard Solar Greenhouse- 1975

- built to test materials to be used in the PEI Ark
- cylindrical outer fiberglass glazing for stiffness and diffusion
- multiple inner layers of "Heat Mirror"
- reflective insulated north roof
- cement fish pond in-ground
- large soil bed at pond level

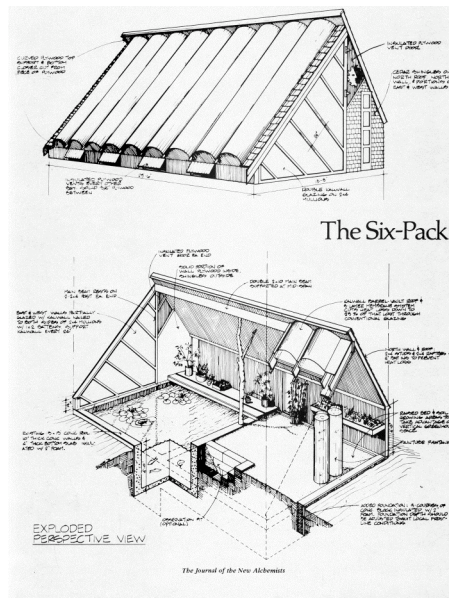

Earle Barnhart  
2/11/07

## The Cape Cod Ark 1976-1989

The Ark was an early exploration into synthesizing ideas of solar heating, winter food production, fish farming, and indoor ecological agriculture. Built as a research bioshelter in 1976, it was used to study the energy dynamics of solar structures and the biochemistry and ecology of contained ecosystems. The research showed that a specialized solar greenhouse in the Cape Cod climate could maintain a healthy, livable interior climate and could produce fresh food, needing minimal winter fuel.



1976 Ark

## The Cape Cod Ark 1989 - 2006

The Ark has gone through several reglazings and renovations. It has been connected to an energy-efficient house on the north, and has solar panels to provide electricity and heat to the house. The Ark is 90 feet long, contains about 1800 square feet of growing space, and has enough height for small trees and overhead vines. Growing inside are a diverse community of plants and a number of large solar fish ponds that are also an important part of heating and cooling the greenhouse.



The original Ark;

- designed and built by Solsearch Architects (now BGHJ Architects, PEI Canada)
- 90 feet long; insulated north roof
- double-fiberglass concave south glazing, supported by cable-trussed rafters to minimize shading
- large top vent, no low front vents
- heat management :
  - 9 fish ponds, above-ground, 700 gallons ea.
  - rock box thermal mass for heat storage; hot air fanned to store solar heat and distribute warm air at night
  - cement foundation insulated on outside
- plants in deep soil beds on several levels
- rainwater from north roof is channeled into a cement pond inside
- diverse food crops grown year-round
- permanent populations of beneficial insects to control pests



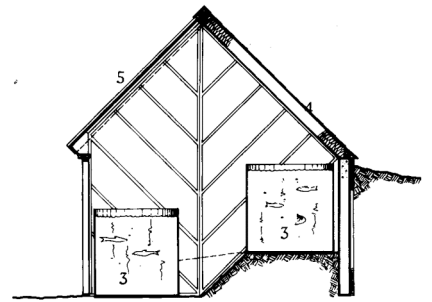
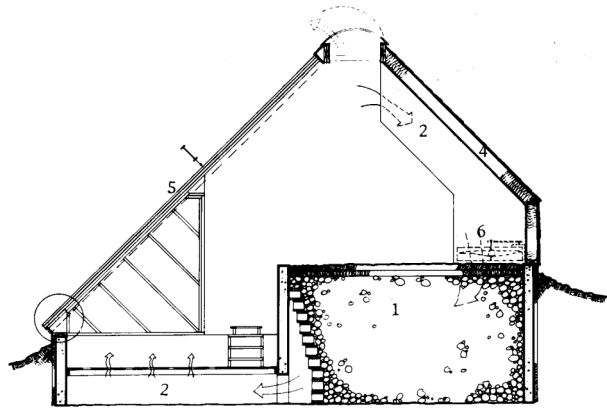
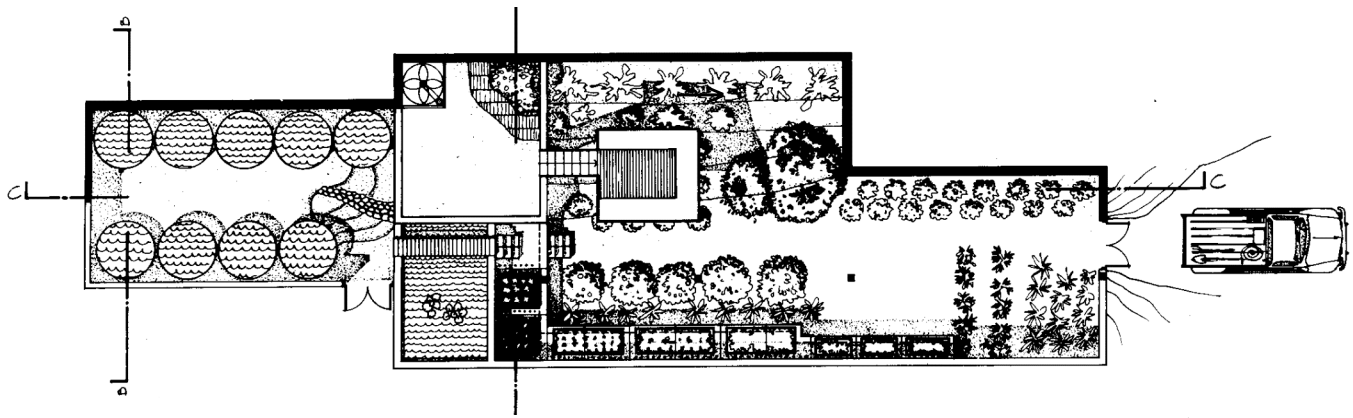

Earle Barnhart  
2/11/07

# Cape Cod Ark - 2007

- steel frame
- glazing with glass and triple-layer polycarbonate
- additions of bottom and top vents
- new solar house attached to the north with a high connecting roof
- rock box chamber used for solar hot water storage
- PV solar panels (electricity) and solar hot water panels



Solar Ponds

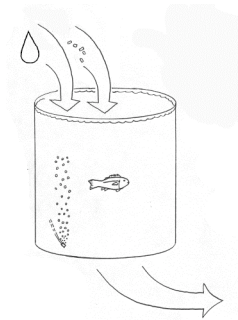
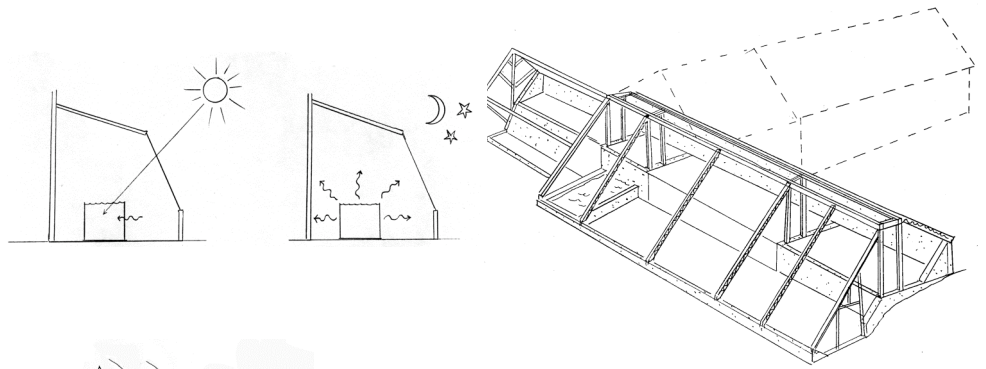

Solar Ponds, Lemon Trees



Aquaculture



Vegetables

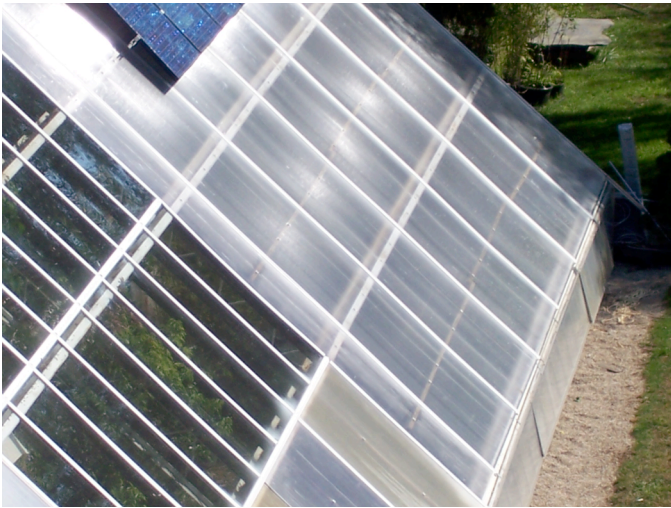

Ark-House Interior  
Architect : Atema Architecture, NY

Earle Barnhart  
2/11/07

## Prince Edward Island Ark – 1976

- designed and built by Solsearch architects (now BGHJ PEI, Canada)
- combines greenhouse, residential house, storage/barn space, solar aquaculture ponds, and active solar hot air and hot water heating systems .
- designed for extreme cold winters and low winter sun angles

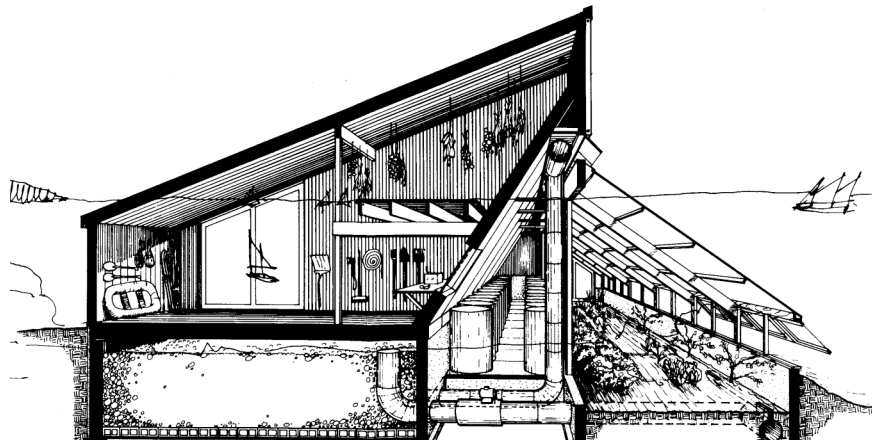

Table 2. Bioshelter 2: Ark on Prince Edward Island

<b>Structure</b>				
Length	110 ft		(33.53 m)	
Maximum width	48 ft		(14.63 m)	
Total floor area	5636 ft <sup>2</sup>		(523.58 m <sup>2</sup> )	
Food culture area (aquaculture and greenhouse)	2605 ft <sup>2</sup>		(242 m <sup>2</sup> )	
Laboratory	152 ft <sup>2</sup>		(14.12 m <sup>2</sup> )	
Living component	1247 ft <sup>2</sup>		(115.85 m <sup>2</sup> )	
Barn	440 ft <sup>2</sup>		(40.88 m <sup>2</sup> )	
<b>Climate</b>				
Solar collection				
(a) Hot water collectors	850 ft <sup>2</sup>		(78.97 m <sup>2</sup> )	
(b) South facing translucent roof	2500 ft <sup>2</sup>		(232.25 m <sup>2</sup> )	
Total	3350 ft <sup>2</sup>		(311.22 m <sup>2</sup> )	
Heat storage				
(a) Hot water	21,000 gal		(79,485 liters)	
(b) Solar ponds	19,000 gal		(71,915 liters)	
(c) Rock chamber	118 yd <sup>3</sup>		(90.27 m <sup>3</sup> )	
(d) Structure interior including concrete				
Estimated usable stored heat: 24 million Btu's (6.05 million kcal)				
Heat transfer				
(a) Air circulation				
(b) Heat pump and hot water circulation				Insulation value
Construction materials				
Roof: galvanized sheet metal over plywood				U factor
0.5 – 1 ft (15–30 cm) fiberglass insulation				U factor
Walls: Standard with 4 in (10.16 cm) fiberglass and foam outside				.03
Shutters under translucent roof: 1 in (2.54 cm) form core construction				.07
Translucent roof				.10
Over greenhouse,				
Aquaculture zone: Roha glass plexiglass FDP—twin sheet .63 (16 mm)				.55
<b>Food-producing systems</b>				
Aquaculture facility: 40–4 ft diameter × 5 ft high				
Interconnected solar fiberglass ponds = 18,800 gal (71,158 liters)				
Commercial plant-growing area = 1000 ft <sup>2</sup> (92.90 m <sup>2</sup> )				
Resident's interior garden area = 240 ft <sup>2</sup> (22.30 m <sup>2</sup> )				
<b>Energy budget</b>				
	Coldest months			
Monthly:	Nov.	Dec.	Jan.	Feb.
Hours bright sun	96	75	110	135
Total solar collection <sup>(a)</sup> in million Btu's	35(8.8)	28(7.1)	40(10.1)	50(12.6)
HYDROWIND* windplant (25 kilowatt) ≈	24(6.1)	24(6.1)	24(6.1)	24(6.1)
(average wind velocity: 14–17 m.p.h. in million Btu's				
Temperature: average	1.5°C	–4°C	–8°C	–8.5°C
Total heat loss in million Btu's	24(6.1)	36(9.1)	45(11.3)	46(11.6)
Surplus heat in million Btu's	35(8.8)	16(4)	19(4.8)	28(7.1)
Surplus heat million Btu's	28.9(7.3)	9.9(2.5)	12.9(3.3)	21.9(5.5)
After non-heating systems subtracted = 6.1 million Btu's				
Surplus heat = without HYDROWIND*	+11(2.8)	–8(–2)	–5(–1.3)	+4(1)
Electricity generation in million Btu's <sup>2(b)</sup>				

<sup>(a)</sup> Figures in parenthesis in million kilocalories.

\* HYDROWIND: Trademark N.A.I. electricity generating 25 kilowatt wind plant.

<sup>(b)</sup> During December and January auxillary heating from wood stove and heat pump will be necessary.

## Paul Sun's Village Dome - 1980

- concept/design by Paul Sun, Architect, Boston MA.
- presented in New Alchemy's "The Village as Solar Ecology - Design Conference Proceedings"
- combines village-scale dome bioshelter with earth-sheltered housing
- each house opens to both interior and exterior spaces
- design allows rainwater catchment and gravity distribution, as well as multi-unit utility services of heat/water/electricity

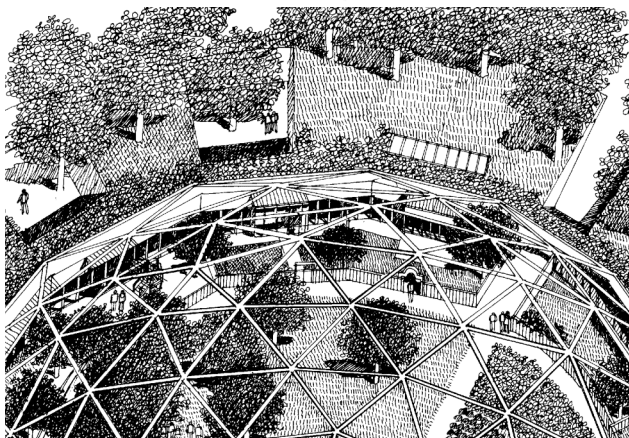
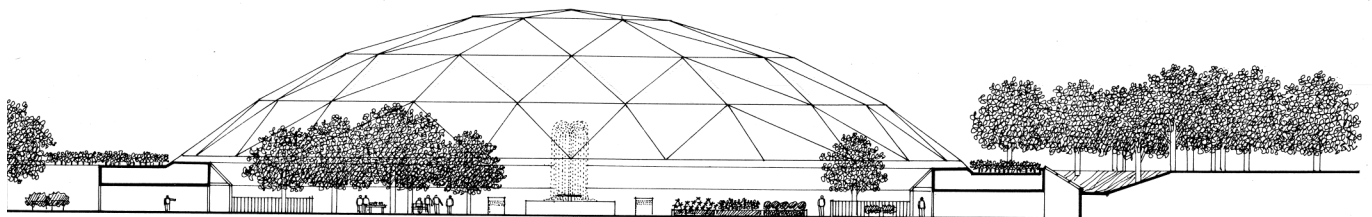
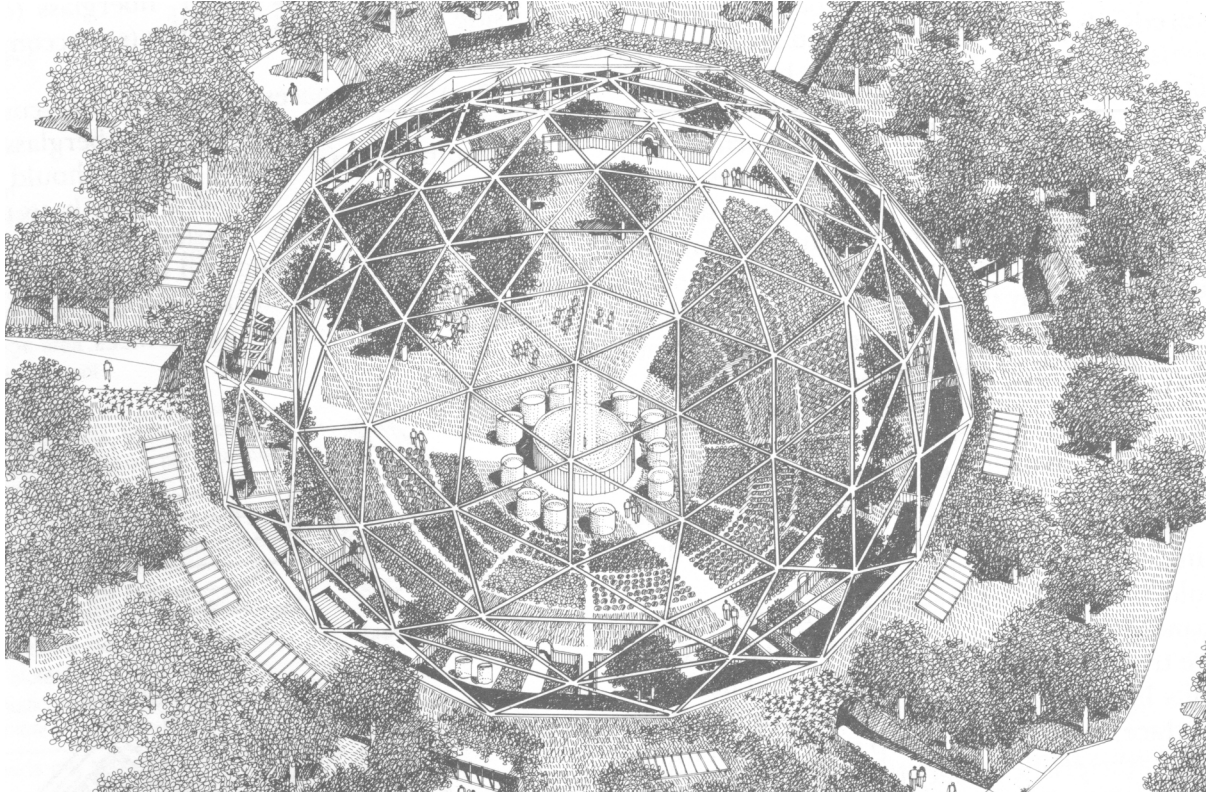

Large-scale domes are made by Foiltek Co. Germany

Earle Barnhart  
2/11/07

## Arkipelago : A Bioshelter Apartment – 1980

- by Jan Atkins, presented in New Alchemy's "The Village as Solar Ecology-Design Conference Proceedings"
- designed for Maine climate
- each apartment has both interior and exterior views and access

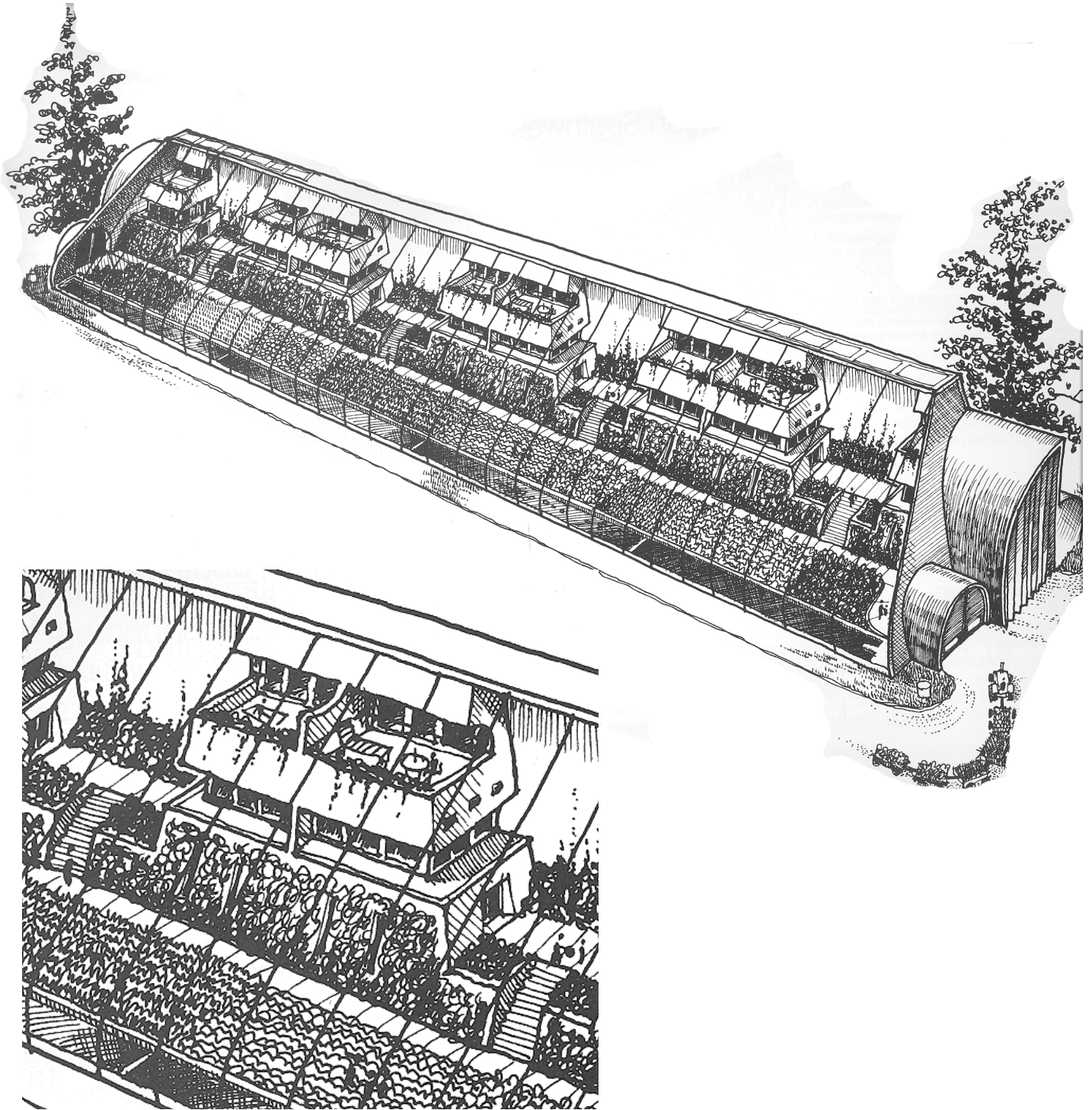

## Malcolm Wells' Meandering Greenway - 1981

- designed by Malcolm Wells, based on sketch by John Todd
- this bioshelter creates a year-round greenway meandering through a landscape, adapting to slopes and contours
- lines of solar ponds inside serve as thermal mass, aquaculture, irrigation, rainwater storage, and wastewater purification, and as linear rivers to move water from place to place.

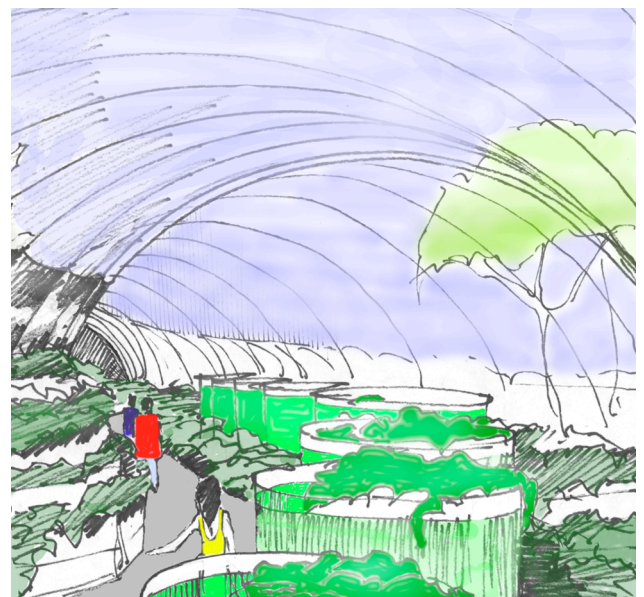
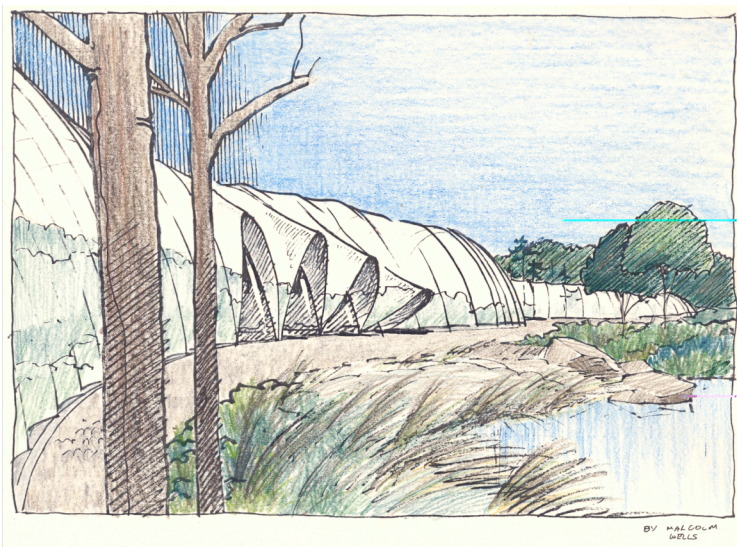
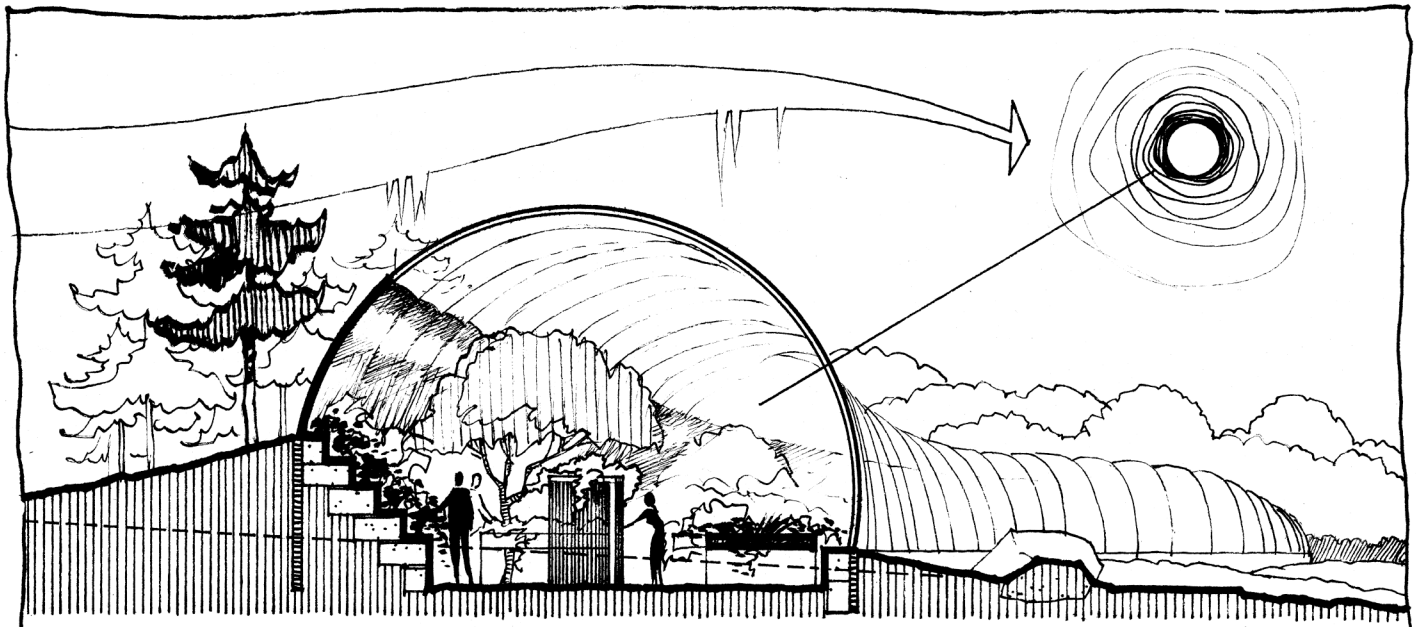
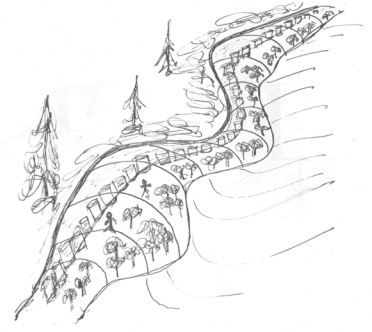

## Pillow Dome - 1982

*"Imagine living outdoors indoors in a transparent dome, picking organically grown vegetables right in your kitchen, sleeping in a bed under luxuriant trees or slung beneath the opened apex, comfortable regardless of the weather outside. Your autonomous garden home is heated and cooled by the sun, which also provides electricity and hot water. Solar heat is stored in translucent water tanks that nurture edible fish and furnish nutrient rich irrigation water for the plants ..."*

J. Baldwin. "The Garden of Eden" Buckyworks 1996.

- designed and built by J. Baldwin, at New Alchemy, Cape Cod
- 50 foot diameter, aluminum tube frame, lightweight structure, minimum shading
- triple-wall inflated pillows made of Tefzel (a fluoro carbon polymer), inflated with argon gas
- 5 triangular pillow vents at top, 5 vents at bottom



# Computer Modeling of Bioshelters - 1981, 1982

“Modeling and Design of Future Bioshelters” Joe Seale and John Wolf. Journal of the New Alchemists - 7

- computer simulations of domes and other shapes to predict light levels and temperature extremes.
- also analysed solar ponds as thermal mass and effects of infiltration rates

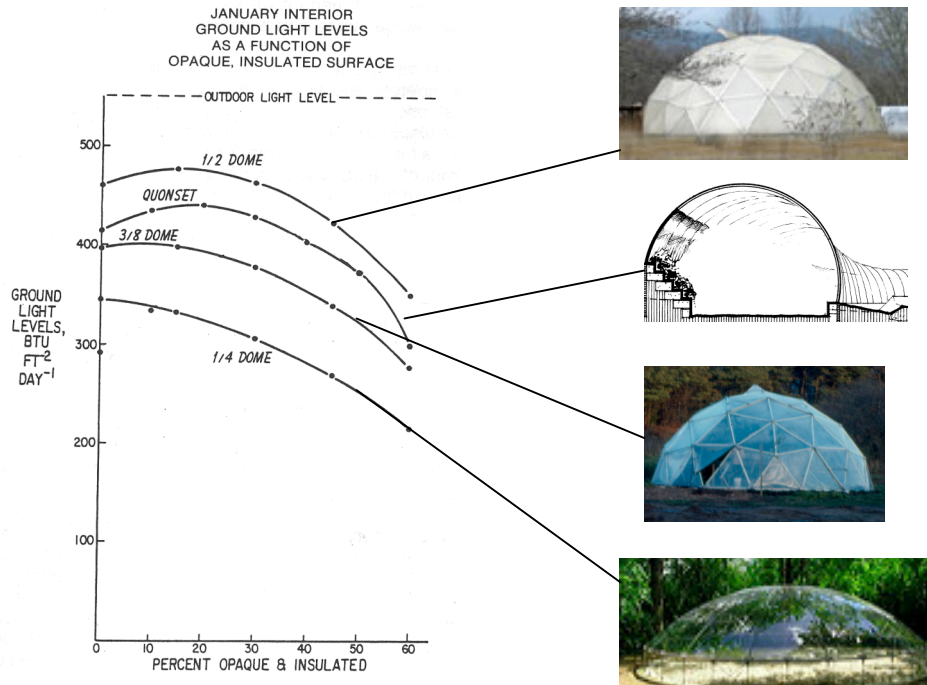

For all shapes except the shallowest dome, some reflective insulation up the north wall to about 15 degrees results in higher light levels on the ground, since some light that would have gone out the north wall is reflected back inside.

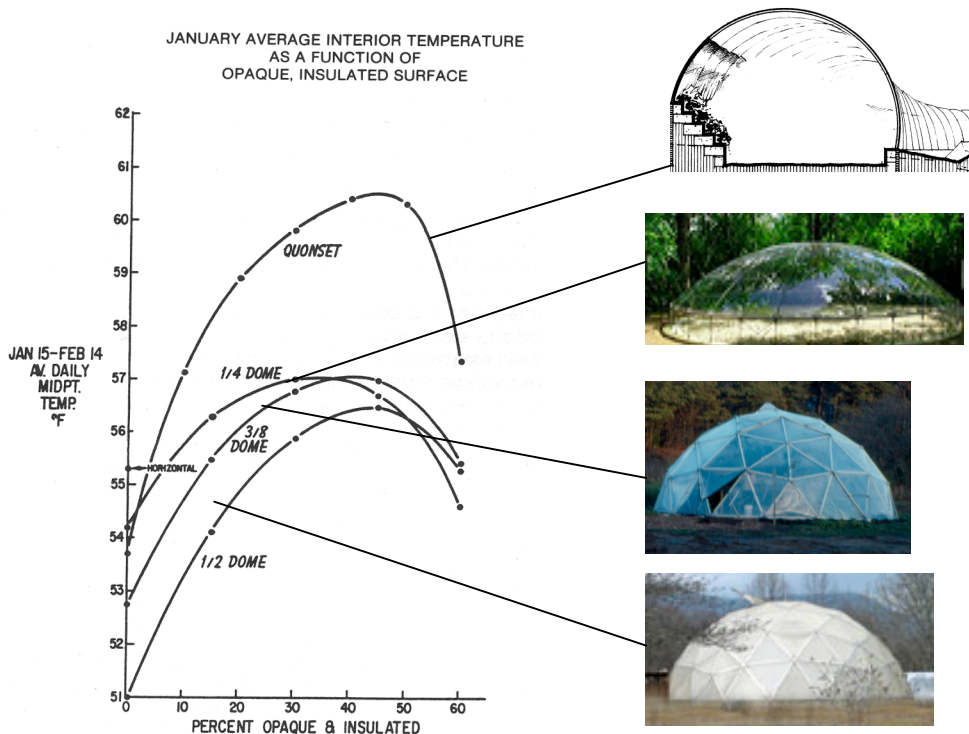

For all shapes, reflective insulation up the north wall to about 40 degrees results in higher interior temperatures, since some heat that would have gone out the north wall is retained inside. However, light levels are reduced

Note that a quonset shape maintains significantly higher temperatures than the other shapes.

Figure 4.  
Note: The graphs assume triple glazing and no night curtain.

## Residential Quonset Bioshelters – 1983

- designs proposed by Earle Barnhart as residential bioshelter concepts
- quonset shaped
- suited for rainwater catchment, water storage and gravity distribution
- internal thermal mass wall for utility lines, water storage, heat management equipment
- rubber membranes control water storage and drainage

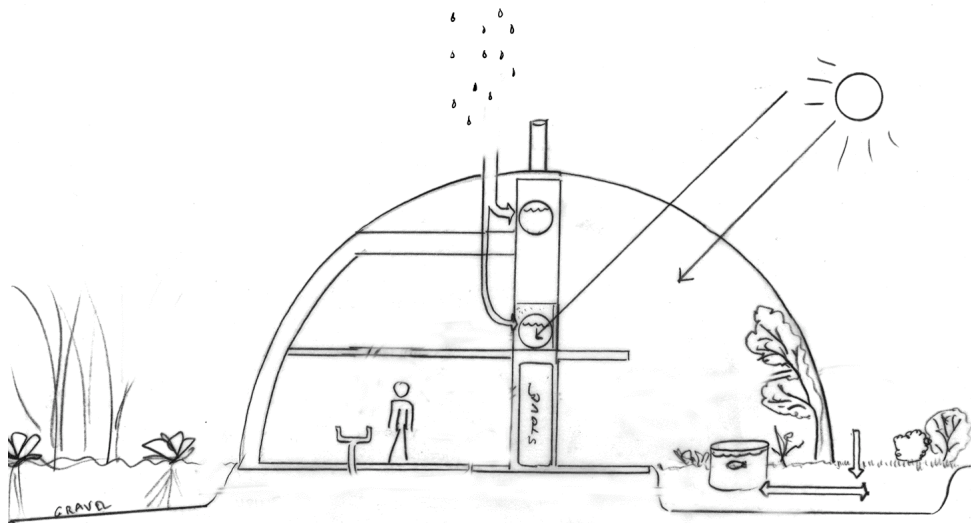
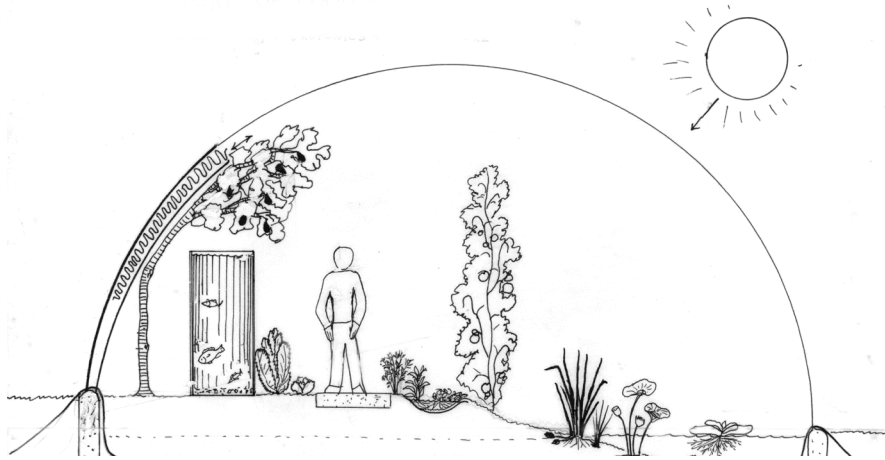
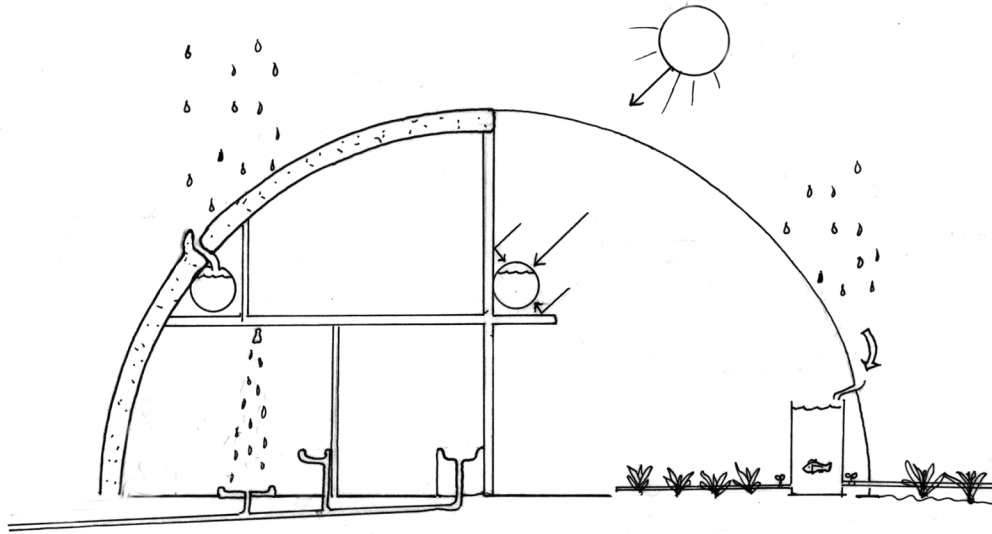

Earle Barnhart  
2/11/07

# Oliva Residential Bioshelters - 1983

- designs by architect Frank Oliva to New Alchemy as residential bioshelter concepts
- half greenhouse, half residence
- rainwater collected from house roof, stored and gravity-distributed to multi-level ponds and plant beds
- multi-family version (below) with wood stove residential back-up

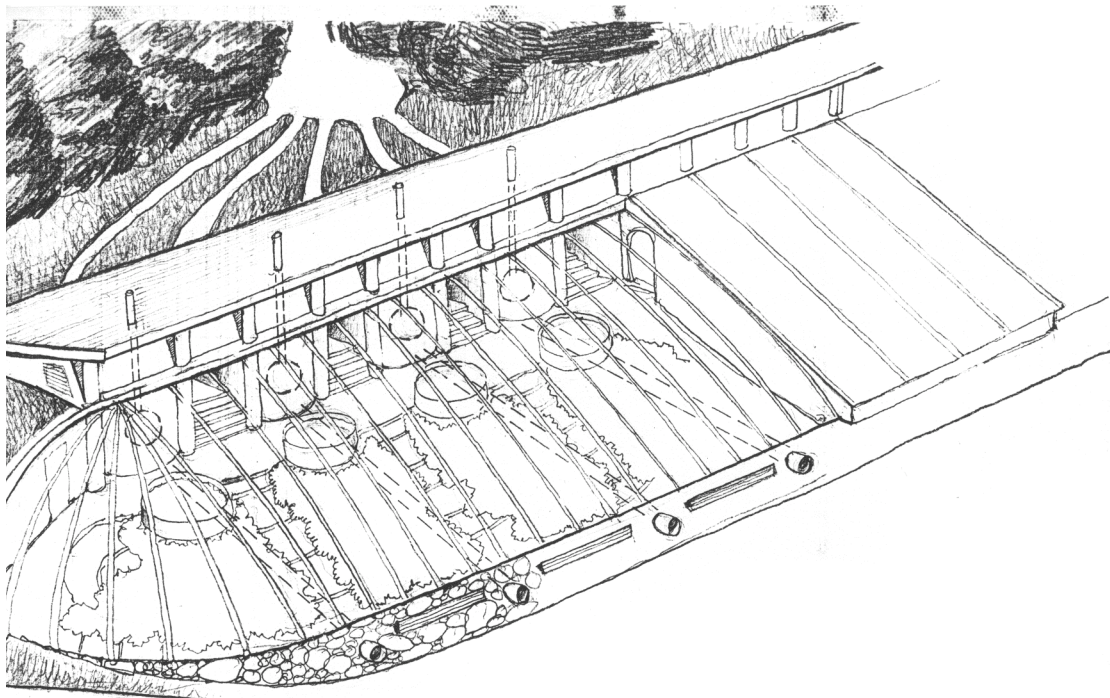
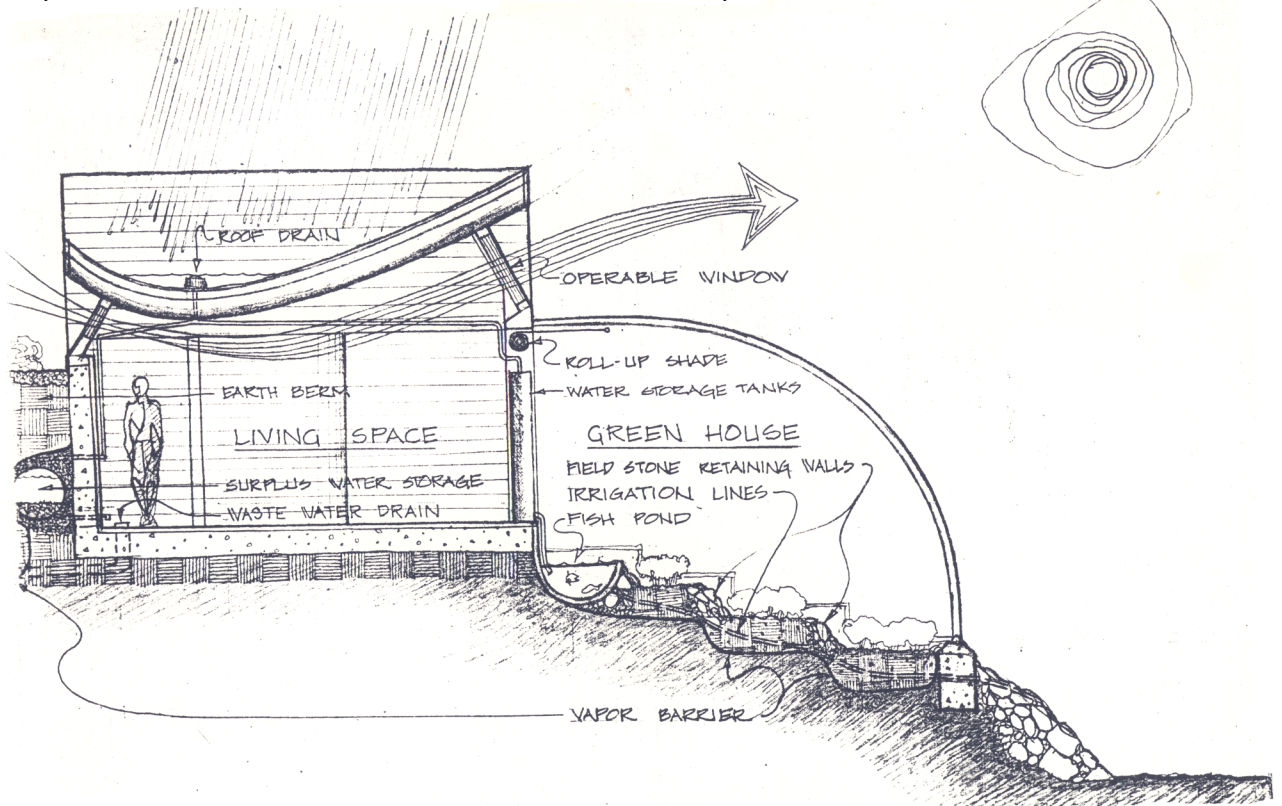

## Composting Greenhouse -1984

- designed and built by Bruce Fulford, at New Alchemy, Cape Cod.
- used to research the concept of heating a greenhouse with the heat from compost
- inexpensive hoop house; double polyethylene, inflated glazing
- compost chambers on north side release heat and CO<sub>2</sub> into greenhouse

Since 1984, we have been using horse manure to heat this 600-square foot prototype greenhouse. The Composting Greenhouse evolved from the centuries-old French "hot bed" method of heating glass cold frames in the winter. Using compost for heating has several advantages: it eliminates the need for external energy inputs and synthetic fertilizers and processes raw manure into finished compost which can then be used as a soil amendment in the garden.

The manure is loaded through removable, insulated panels on the exterior north side of the greenhouse. While decomposing, it gives off heat, water vapor, nitrogen gases and carbon dioxide, all essential elements for plant growth. Blowers transfer the warm, moist air through ducts into the soil beds. During winter months, each bin is emptied biweekly and fresh manure installed to assure a constant supply of heat. The steady bottom heat and rich air are excellent for seedlings. Ongoing research looks into the best type of filter media to allow nitrogen gases to be converted into usable forms.

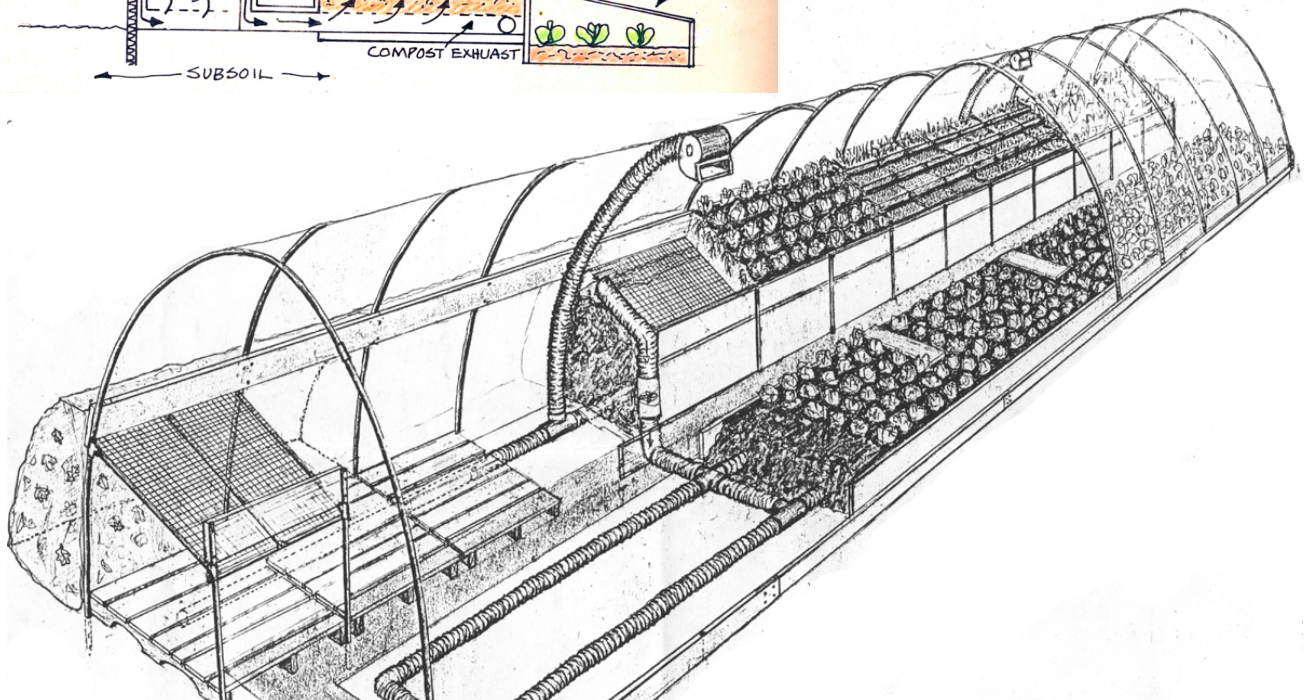
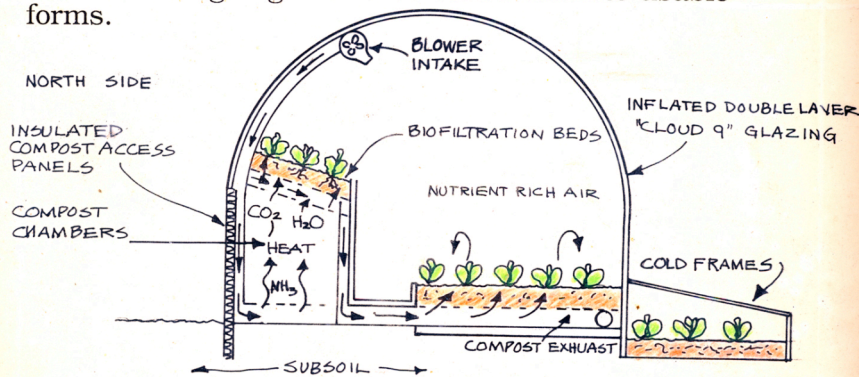

# Future Bioshelters

While New Alchemy's work offers promising directions for future bioshelters, many other researchers have created bioshelter structures that contain valuable concepts :

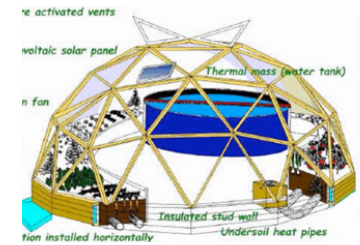
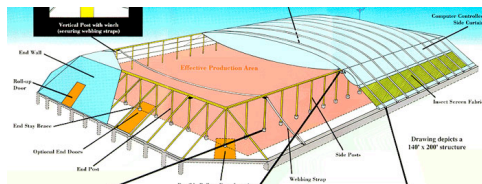
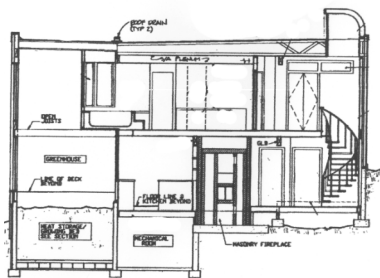
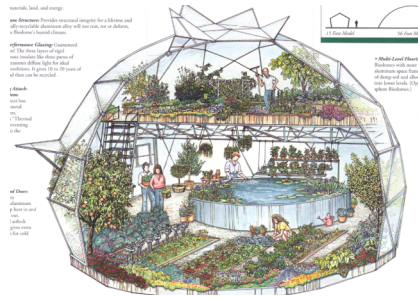
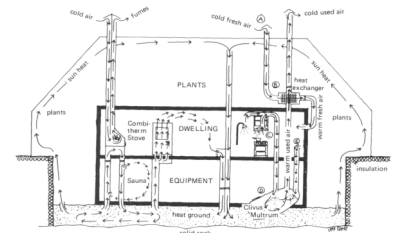

... and others...

*Based on this combined experience, it is clearly possible to construct permanent bioshelters that could provide a wide range of basic human needs in an ecological manner.*

*So why not make them for everybody. A few million bioshelters would go a long way towards a humane transition for a petroleum-challenged society, and would cost a lot less than a good-sized war. Think of it as a sort of insurance against local economic disruptions and the vagaries of international energy supplies.*

EB

Be the change you want to see in the world.

Mahatma Gandhi



## REFERENCES – Publications by New Alchemy Institute

- The Journal of the New Alchemists No. 2 1974 134 pp. editor Nancy Jack Todd [selected articles]  
“New Alchemy’s Ark ...” by Robert Angevine, Earle Barnhart, & John Todd  
“Walton Two: A Compleat Guide to Backyard Fish Farming” by Wm. McLarney & John Todd. pp 79–115.  
[ a working manual of tilapia aquaculture reviewing previous 3 year’s research.]
- The Journal of the New Alchemists No. 3 1976 130 pp editor Nancy Jack Todd [selected articles]  
“An Ark for Prince Edward Island” by John Todd
- The Journal of the New Alchemists No. 4 1977 150 pp. editor Nancy Jack Todd [selected articles]  
“ Tomorrow is Our Permanent Address” by John Todd [ bioshelter concepts & PEI Ark details ]  
“Bioshelters as Organisms” by Ron Zweig  
“Bioshelter Primer” by Earle Barnhart  
“The Six-Pack : A Backyard Solar Greenhouse” by Laura Engstom
- The Journal of the New Alchemists No. 5 1979 154 pp editor Nancy Jack Todd [selected articles]  
“Biotechnic Strategies in Bioshelters” by Earle Barnhart  
“Soundings from the Cape Cod Ark” by Kathi Ryan  
“Where Does All the Heat Go?” by Joe Seale [ a computer model to calculate heat in the PEI Ark]
- The Journal of the New Alchemists No. 6 1980 186 pp. editor Nancy Jack Todd (publ Stephen Green Press)  
[selected articles]  
“The Energetics of Solar–Algae Pond Aquaculture by John Wolfe  
“From Our Experience : The First Three Years Aboard the Cape Cod Ark”  
by NAI staff and Solsearch Architects
- The Journal of the New Alchemists No. 7 1981 178 pp editor Nancy Jack Todd (publ Stephen Green Press )  
[selected articles]  
“Logging the Course of the Ark :  
“Indoor Gardening” by Colleen Armstrong  
“Controlling the Whitefly” by Colleen Armstrong  
“ Toxic Materials in the Bioshelter Food Chains & Surrounding Ecosystems”  
by Dr. Han Tai, Colleen Armstrong, and John Todd  
“Modelling and Design of Future Bioshelters” by Joe Seale & John Wolfe  
“The Village as Solar Ecology” Nancy Jack Todd & John Todd  
“Energy And Architecture :  
“Solar village Principles & Construction Ideas” by Malcolm Wells.  
“A Dome Bioshelter as a Village Component” by J. Baldwin.
- MISC. REPORT : Observations of Plant Response and Food Production in Solar Bioshelters. November 1977. 14 pp.  
by Kathi Ryan & Earle Barnhart [ report on maiden winter of Cape Cod Ark, built in fall 1976 ]
- TECHNICAL BULLETIN # 3. Notes on Greenhouse Agricultural Management. by Colleen Armstrong. 8 pp.  
TECHNICAL BULLETIN # 7. Controlling Aphids in the Greenhouse. 9 pp. Colleen Armstrong, Steven Chamay,  
Richard Heiman, Constance Wiseman
- RESEARCH REPORT 1–A . Greenhouse CO2 Dynamics and Composting in a Solar Heated Bioshelter. 1979. 19 pp.  
by Robert “Sardo” Sardinsky.  
Published in “ Solar Greenhouses : Living & Growing” – Proceedings of 2<sup>nd</sup> Natl  
Energy–Conserving Greenhouse Conference. p 22–40. Am. Solar Energy Society.
- RESEARCH REPORT 1–B Importance of Carbon Dioxide in Greenhouse Crop Production :  
A Greenhouse CO2 Dynamics Primer.  
Nov 1 1978. 35 pp. by Robert “Sardo” Sardinsk
- “Assessment of a Semi–Closed, Renewable Resource–Based Aquaculture System  
Progress Report No. 3 appendices :  
IX. Agriculture & Aquaculture in Bioshelters : The New Alchemy Experience. by John Todd & John Wolfe.  
X. The Energetics of Solar Pond Aquaculture. by John Wolfe

New Alchemy Quarterly : [selected articles]

4. Winter Solstice 1980.
  - Notes on Greenhouse Agricultural Management. by Colleen Armstrong. 12 pp.
  - Bioshelters – Pillowdomery by J. Baldwin
7. Winter 1981/1982. 24 pp.
  - Bioshelter . by John Wolfe
  - Relative Insulating Properties of Gases. by Joe Seale
9. Summer 1982 Second Generation Bioshelters 24 pp.
  - Tefzel
  - The Pillow Dome Opening : The Modern Age of Bioshelters Begins. by Gary Hirshberg
  - The Latest Year of Research on Bioshelters : A Summary. by John Wolfe
  - [Fish] Breeding in Bioshelters. by Linda Gusman
  - Bioshelters : How's the Dome Project doing? by J. Baldwin
  - Heat Transfer with Insulating Gases. 12 pp. by Joe Seale.
13. Fall 1983: Naives and Visionaries 20 pp.
  - Overall, the Pillow Dome is working well. by Daryl Bergquist
14. Winter 1983: 24 pp.
  - Some New Ideas for Residential Bioshelters. by Earle Barnhart
  - How Warm are Our Bioshelters? by Daryl Bergquist
18. Winter 1984.. Do Integrated Systems Really Work Better? . 24 pp
  - Infrared Radiation Heat Loss Through Greenhouse Glazings. by Daryl Bergquist.
19. Spring 1985: Growing Food in Water: The Art & Science of Aquaculture and Hydroponics. 24 pp.
  - Evaluation of Biological Islands for Control of Greenhouse Whitefly. by Richard Meadows.
21. Fall 1985: Beating the System. 24 pp.
  - An Aphidoletes aphidimyza Update. by Colleen Armstrong
  - The Economics of Food-Producing Greenhouses in the Northeastern US. .by Norm Marshall
29. Fall 1987: Solar Greenhouses. 24 pp.
  - Refurbishing the Ark. by Mark Ward

**BOOKS :**

The Village As Solar Ecology, : Proceedings of the New Alchemy/Threshold Generic Design Conference of April 1979.  
1980. 135 pp. editors John Todd and Nancy Jack Todd.  
The Book of the New Alchemists, 1977. 176 pp. edited by Nancy Jack Todd. publ. E.P. Dutton, New York.

**WORKING PAPERS :**

1. The Pillow Dome Bioshelter : part I, data analysis. Joe Seale, Daryl Bergquist, and John Quinney. Fall 1983
2. The Pillow Dome Bioshelter : part 2 – test cell investigations. Daryl Bergquist and Joe Seale Spring 1984.
5. Studies on the suitability of several sages and scented geraniums as host plants for greenhouse whitefly Trialeurodes vaporariorum Westwood and its parasite Encarsia formosa Gahan . Fall 1984. by Richard H. Meadows.
6. Integrated pest management in bioshelters : research & education. Dec 1984. Colleen Armstrong & John Quinney  
(A final report to the Massachusetts Society for Promoting Agriculture)
7. Non-chemical pest control for year-round food production in cold climates : research and education. April 1986  
Colleen Armstrong and John Quinney. ( A final report to the C.S. Fund)
8. Collaborative projects involving the egg-parasitic wasp, Edovum puttleri. December 1985. Bugg, R.L.
15. The market for the residential bioshelter. Oct 1985. Norm Marshall

**REPORTS ABOUT THE ARK ON PRINCE EDWARD ISLAND, CANADA**

( the Ark on PEI was built by New Alchemy PEI in 1976, and operated by NAI PEI until 1978.  
The PEI Canadian provincial government then managed it until June 1981. )  
“An Ark for Prince Edward Island : A Report to the Federal Government of Canada”. Dec 30, 1976.  
Book 11” h x 22” wide. 78 pp.  
By John Todd, Robert Angevine, Solsearch Architects, Tyrone Cashman.  
[ poster ] The P.E.I. Ark. (date ?) 22”x30” by Solsearch Architects, Charlottetown, PEI, Canada.  
“This poster updates the design description in the ‘Journal of the New Alchemists (3). 1976.”  
“The Ark Project – A Year in Review”. Jan. 1981. 8 pp. [an overview of the ark, research findings, and education ]  
[ includes list of 29 publications related to the Ark Project on PEI ]. PEI Ark publication.

**POSTERS :**

“THE ARK – an early exploration in weaving together the sun, wind, biology, and architecture on behalf of humanity”  
by Solsearch Architects & New Alchemy Institute. 20”x28”, 2 sides.

(Full color exterior photograph on one side, architects’ drawing of the interior and how it works  
on the other side.)

“The P.E.I. Ark” by Solsearch Architects, Charlottetown, PEI, Canada. 22”x30”

“This poster updates the design description in the ‘Journal of the New Alchemists (3). 1976.”

**BOOKS BY NEW ALCHEMISTS – OTHER PUBLISHERS :**

“Bioshelters, Ocean Arks, City Farming”. by John and Nancy Todd

2005. “A Safe and Sustainable World – The Promise of Ecological Design” by Nancy Jack Todd. Island Press.

**SELECTED PUBLICATIONS BY NEW ALCHEMISTS :**

Annals of Earth

Annals is a publication of Ocean Arks International. Edited by Nancy Todd, it often describes  
on-going work by New Alchemists or related ideas about ecological sustainability.

Ocean Arks International, 176 Battery Street, 3rd Floor, Burlington, VT 05401

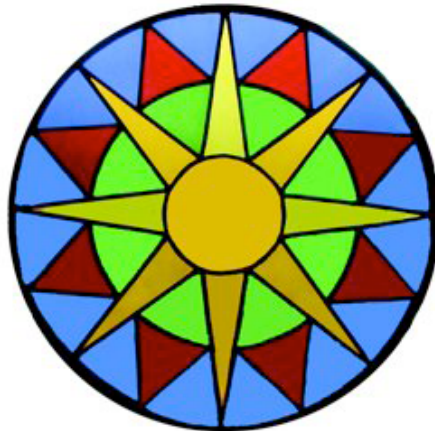

Earle Barnhart and Hilde Maingay  
live in the solar house attached to  
the Cape Cod Ark bioshelter.

